

Drawy

Handly and simply to use



CART

Frequent usage

Emergency

Ambulatory

Home Care

Residential aged care





RETRACTABLE SIDE TRAY

Benefits

- Sturdy and with sheets in stainless steel painted with thermosetting paint
- Single body structure and self-supporting.
- Thanks to its small size it is easy to handle even in narrow places.
- Despite its small size it is actually very capacious.
- Swivable wheels with sliding system for easy driving.
- Push and pull extra tray.
- Anti-tilting structure.
- Table top made in plastic material without sharp edges for easy cleaning and disinfection.
- Drawers in steel sheets, sliding on glides with automatic lock.
- Chiusura cassette centralizzata con chiave.
- Drawers centralized locking system.
- Glides can support up to 30 kg.















Standard features

- Centralized locking system with key.
- Double key.
- No. 4 swivable and stainless wheels of which 2 with pedal brake. No marking, extremely silent, sliding on high performing roller bearing.
- No. 4 bumpers for each corner of the base.
- Push and pull extra tray.
- Table top with integrated push handle.

Colour chart

FRAME COLOURS

The entire structure is protected by epoxy and thermosetting paints. Wether not specified the frame of the device will be painted in white 9010.

| | | |
|---|---|---|
|  Codice 2004 |  Codice 5012 |  Codice 7035 |
|  Codice 3020 |  Codice 6027 |  Codice 9005 |
|  Codice 1018 |  Codice 6018 |  Codice 9010 |
|  Codice 1021 |  Codice 7001 |  Codice 4010 |
|  Codice 5010 |  Codice 9006 | |



Dimensions

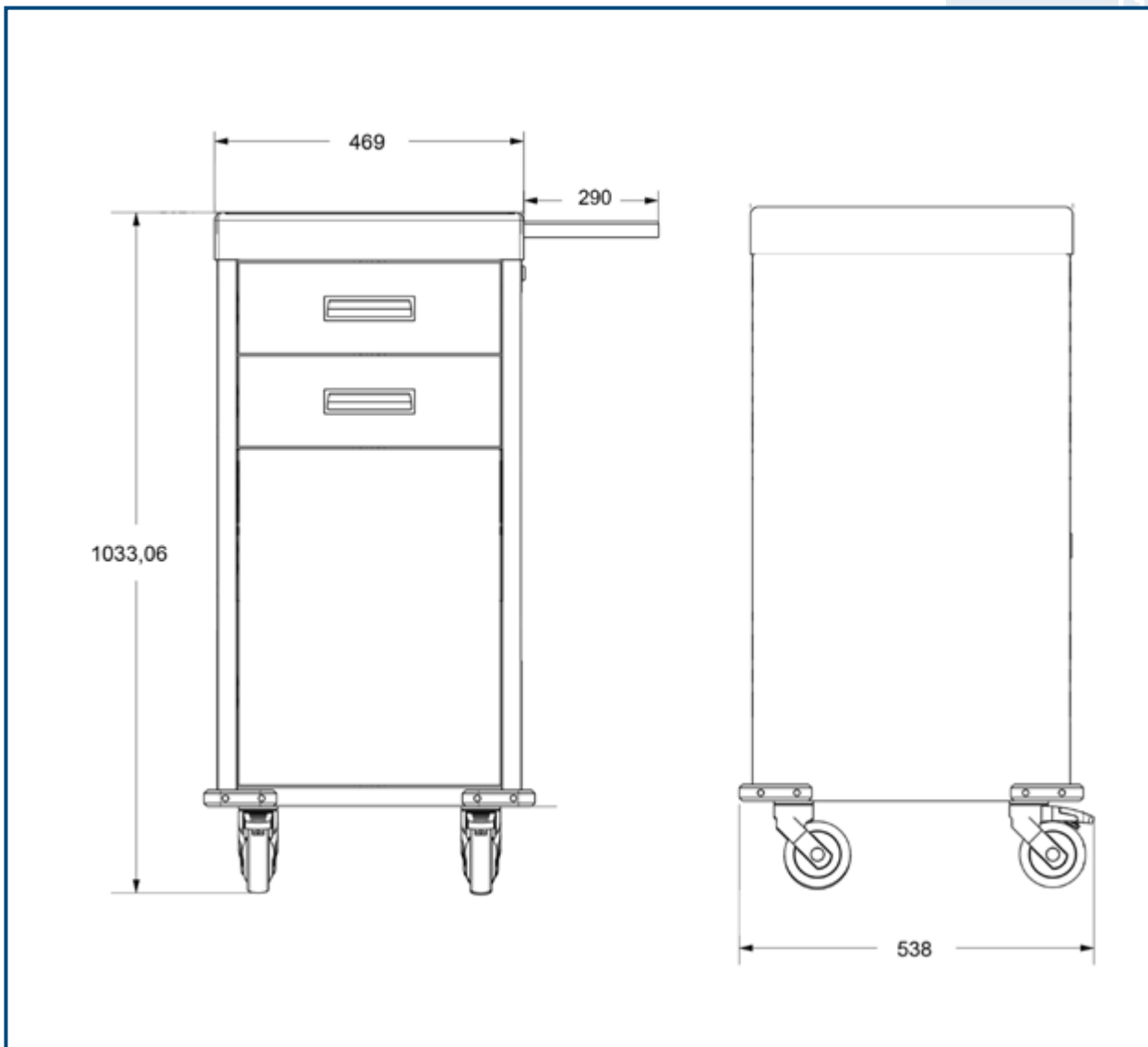

Technical sheet



| | |
|--------------|----------------------|
| GMDN Code | ND |
| ID Code | GB0372.SP |
| Intended use | Multifunctional cart |
| Manufacturer | GARDHEN BILANCE SRL |

Per le certificazioni fare riferimento a quanto specificato nella Sezione "Certificazioni e Sistema qualità"

Le immagini riprodotte in questa scheda sono puramente indicative. È facoltà del produttore apportare ai progetti modifiche senza alcun preavviso. Per l'identificazione delle dotazioni di serie e per la scelta di eventuali ulteriori componenti riferirsi al catalogo accessori e/o alle proposte commerciali. In caso di dati discordanti fa fede il contenuto delle proposte commerciali.

Dep. EN_93 rev. 03/03/2022