

# Anne XL

Optimized system for collecting and transport of hospital waste



## CART

### Frequent usage

Emergency room

Resuscitation

Operating room

Infirmary

Intensive care unit

Dialysis

Hospitalization

Specialistic

## Benefits

- Extremely robust frame made entirely of stainless steel that provides high stability in all operating conditions.
- Especially appropriate for environment with chemical corrosive substance.
- A device that is easily sanitised with commonly used medical surgical aids and detergents.
- A device that is easily sanitised with commonly used medical surgical aids and detergents.
- The handle made with stainless steel tube with high thickness and resistant to intensive use.
- Steel frame with thermosetting powder coating. Wide range of colours page 4.
- Ø 60 mm stainless steel wheels: durable, quiet and non-marking with directional system.
- Agile and manoeuvrable, its small footprint allows easy transport even in low-capacity environments.
- Platform made of HPL, a highly resistant and easily sanitised material. Material colour optionally white or blue.
- The trolley is compatible with the most common containers used in healthcare.
- Configurable with a wide range of modular accessories.
- Bumper on lateral and front side.

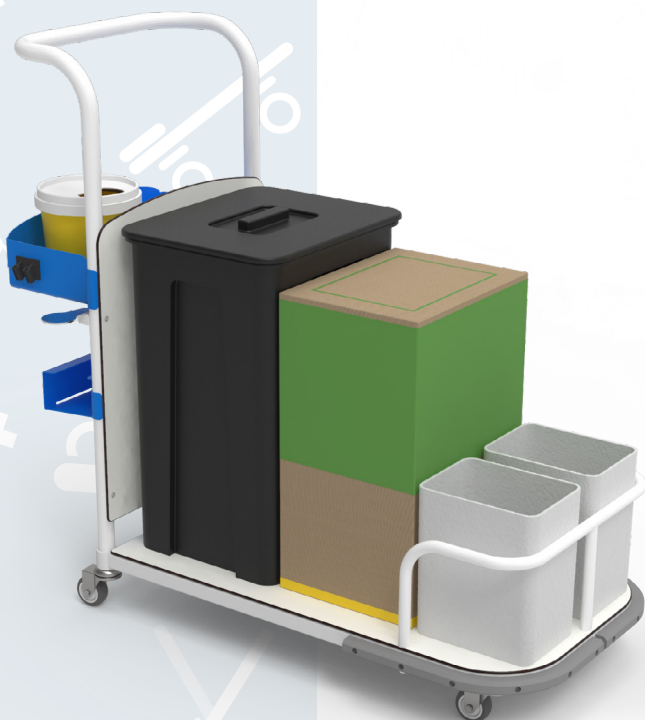

## Accessories available

### ACCRI

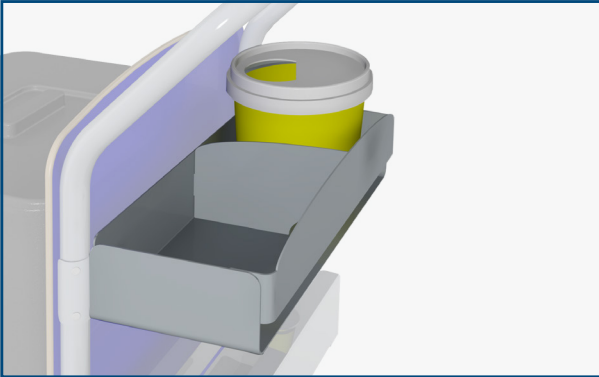

Two-compartment container. Assembled at the transport handle can accommodate a receptacle for sharp waste and other useful material for the purpose.

Useful dimensions:

- L. 200mm x P. 200mm x H. 120mm
- L. 238mm x P. 200mm x H. 120mm

### ACCR2

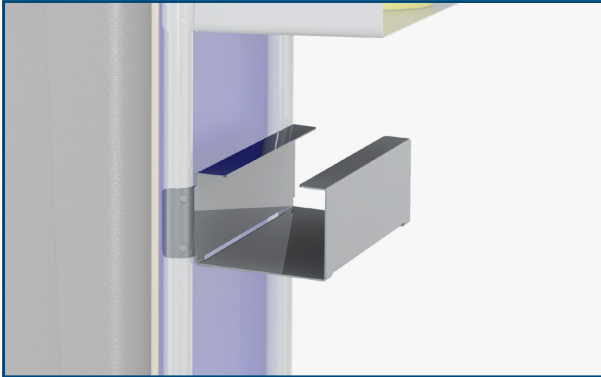

Gloves holder

It fits 2 standard packs of disposable gloves. Inclined for easy grip extraction.

Useful sizes

- L 420mm x P 130mm x H 90mm

### ACCR3



Rotating support useful to fit the needles collecting receptacle.

### ACCR4

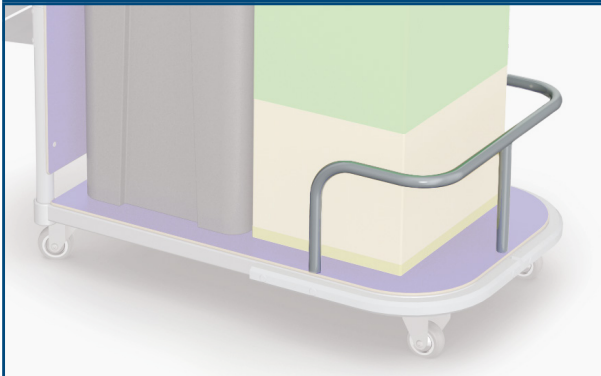

Front containment made with stainless steel, prevents the containers from fall in the front, during movements and trasport.

Dimensions.

- L. 480mm x P. 230mm x H. 200mm

### ACCR5



Side containment frame made with stainless steel, prevents the containers from falling on the side, during movements and transport.

Dimensions.

- L. 480mm x P. 720mm x H. 200mm

### ACCR6



Adhesive support for sharp handling.

## Accessories available



## ACCR7

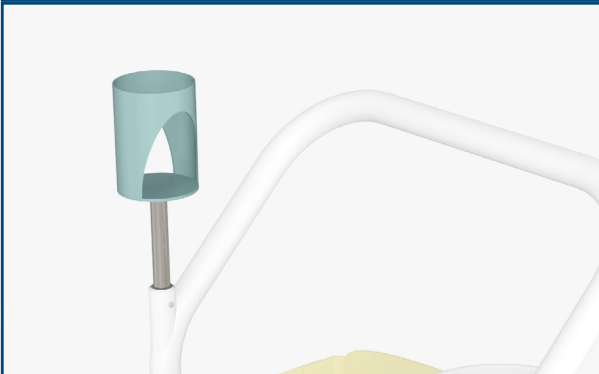

Soap dispenser or sanitising liquid holder, adjustable in height with 3 positions. Diameter maximum of dispenser 100mm.

## ACCF4



Automatic dispenser.

## ACCR8



HPL material tray 50x30 cm. Max. load capacity 10 kg.



**Would you like to customize upholstery or frame?**

Scan or click the QR code and discover how to customize the device consulting our colour chart.



## Dimensions

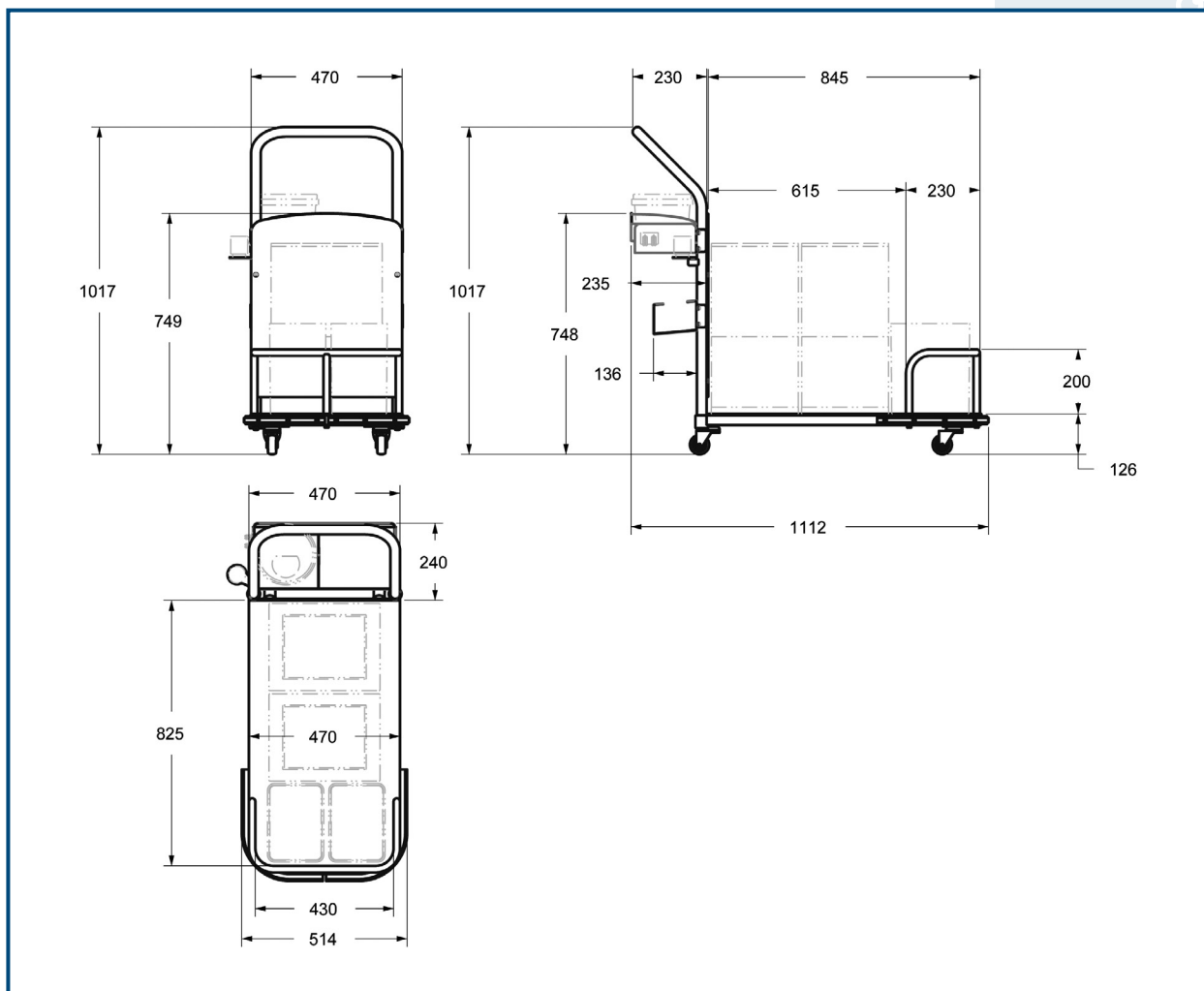

## Technical sheet

Cod. Prodotto	<b>GB0198.SS</b>
Intended use	Special waste collecting
Manufacturer	GARDHEN BILANCE SRL
Wheels	Stainless steel wheels - stainless steel Ø 60mm - swivel
Total weight	15 kg
Maximum capacity	100 kg
Container capacity	x 60lt pvc or cardboard (410x350 x h. 600mm)
Elsa	Tubolare inox Ø 30 mm
Frame material	Steel and stainless steel AISI 304 machined CNC
Flatbed and shoulder	HPL thickness 5 mm CNC machined
Small components	Stainless steel
Bumpers	Front bumpers in shockproof technopolymer
Treatment surface	Zinc-galvanized and painted steel frame with thermosetting powder

For certifications please refer to "Certifications and Quality system" section"

Pictures contained in this brochure is for illustrative purpose only. The manufacturer reserves the right to modify the projects without notice. For accessories identification please refer to the accessory catalogue or commercial offer. When data are different please refer to commercial offer.

Dep. 21 rev. 16/06/2022